

**DMK stay cable system**

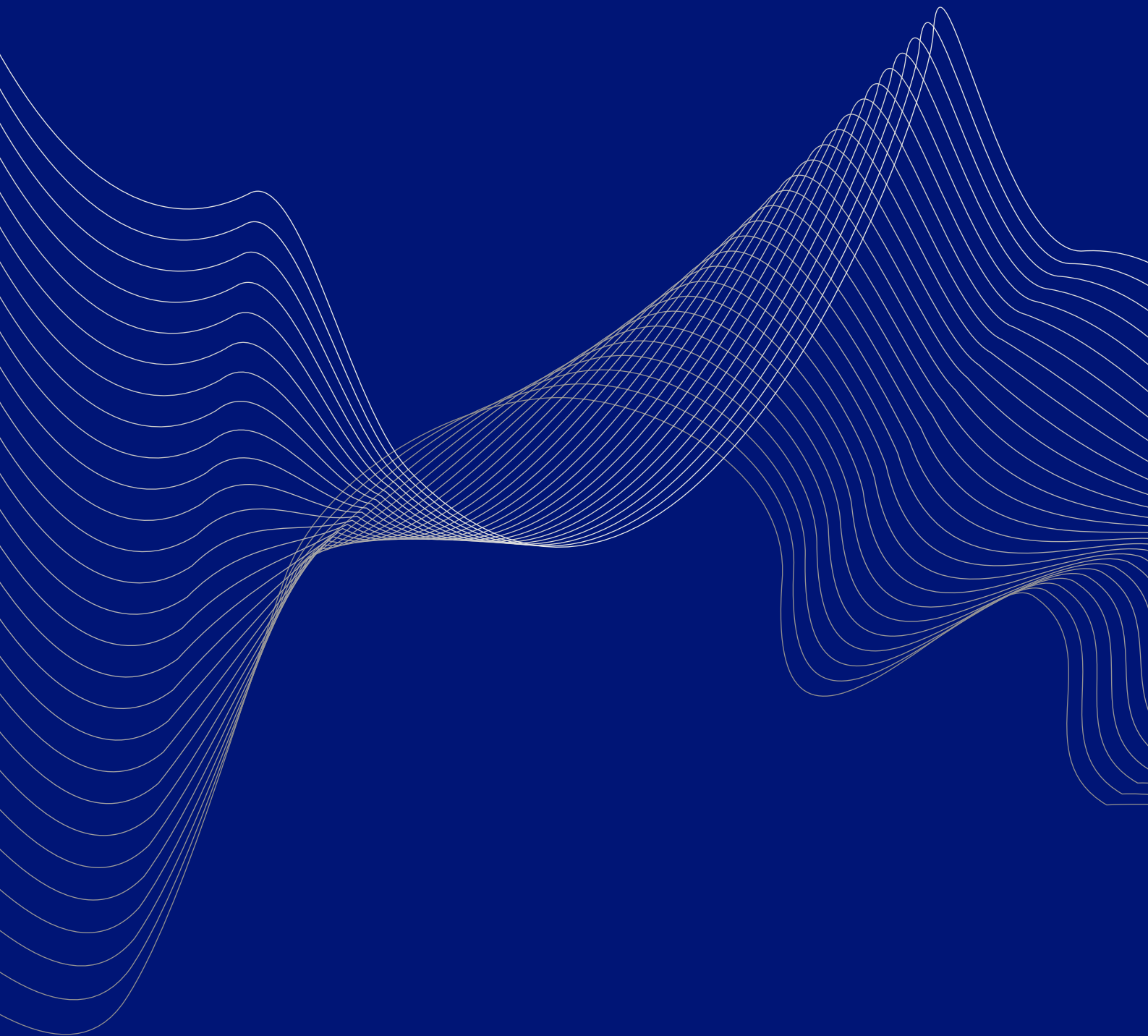

**MK4**  
Innovative Solutions





<b>MK4 STAY SYSTEM</b>	
Introduction	2
DMK Stay	2
<b>DMK STAY</b>	3
Material General Specifications	4
DMK Anchor Heads	5
DMK Parallel Strand Stays Characteristics	7
DMK Adjustable End	8
DMK Fixed End	9
<b>DMK STAY COMPONENTS</b>	
Saddles	10
Strand for the DMK Stay System	
High Density Polyethylene Duct	11
Anti-vandalism Pipes	
Elastomeric Centraliser	12
Dampers for Wind Induced Vibrations	
Monitoring	13
<b>TESTING</b>	
Testing of Stay Cable Systems	14
<b>DMK INSTALLATION</b>	
Anchorage and Duct Installation	15
Strand Threading	
Finishings	16
<b>DMK COMMITMENT</b>	16

The progress of Stayed Bridges has followed the need for bridging larger spans more economically and to the concept of magnificent land marks that these kinds of bridges introduce in the infrastructure networks. Progress equates with the developments in structural analysis and it has been followed by the improvement of Cable Stays since the renaissance of the cable stayed bridge typology in 1955.

The different structural stay types have taken their own specialized place depending on the nature of their tensile element and the characteristics of the structure to stay.

Parallel Strand Stays have become the referent solution when conditions ask for high loads and high dynamic performance. This kind of stays have drastically evolved in the last decade where resin based anchorages and cement or wax grouted stays have led their way to wedge systems only and self protected strands.

The increase of the spans of the modern stayed structures and the subsequent increase in the length of the stays have lead to the introduction of aerodynamic concepts on the design. Further, new elements have been introduced as profiled ducts to break the wind stream and dampers to reduce the wind induced vibrations.

MeKano4 has been involved since its creation with the design and installation of cable stays for bridges and all kind of diverse stayed structures. MeKano4's staff, with more than 20 years experience in cable stays, together with DMK Stay, A.I.E., have developed the DMK parallel strand stay system that fulfils the most demanding project requirements.

## DMK Stay

The DMK Stay belongs to the latest parallel strand cable stay generation.

Stay is based on a bundle of self protected prestressing strands that run inside a global polyethylene duct. Strands are anchored through the wedge system in the DMK anchor heads.

The following premises have been taken into consideration for the DKM Stay design:

- Stay behaviour according to the most relevant international recommendations
- Durability
- Wide size range
- Easiness of installation
- Unitary stressing (strand by strand)
- Adjustable anchorages for full stay stressing or distressing
- Force checking or monitoring at any time.
- Replacement of the stay, as a whole or each strand individually
- Prepared for damper installation
- Adaptable for special solutions

Stay anchor heads have been tested according to the PTI Recommendations for Stay Cable Design, Testing and installation and have achieved the following successfully:

- Dynamic behaviour: 2 million cycles, 200 N/mm<sup>2</sup>, upper load limit 45% GUTS
- Static efficiency: 95% of GUTS (Guaranteed Ultimate Tensile Strength)





Basic stay is fully sealed to avoid the entrance of water inside and comprises at least 4 protective barriers to the steel of the strands at any point, this warrants the maximum durability of the tensile element against corrosion.

Standard sizes are composed of 7 to 127 strands with 0.6" diameter.  
The strand to be used can either be 15.2 or 15.7 mm. nominal diameter.

The strand holes at the anchor heads and inner deviators are large enough to allow the self protected strand and its envelope to go through. These characteristics allow the insertion "in situ" of the strands from the outer surface of one of the anchor heads, avoiding the need to pre-cut or pre-peel them before threading. This advantage reduces threading time and considerably makes the stay installation easier. It also permits the replacement of a stay strand by strand as stressed strands do not impede the access or movement of the one being replaced.

All DMK anchorages either adjustable or fixed types, allow unitary stressing with a monostrand jack. This gives freedom to decide where to place the adjustable end for global stay force checking or regulation and where to stress strand by strand.

During installation, force can be checked at individual strands at any time with monostrand jacks. After strand tails are cut, Stay force can still be checked or regulated with global hollow jacks that are threaded at the anchor plate of the live end. Also, as an option, anchorages can be equipped with electro-magnetic sensors that permit the force monitoring of certain strands during all the stay life.

The stay constitutes an independent element of the structure. DMK Stays are encapsulated forming one sealed unit. They are linked to the structure only by the bearing of the anchor head nuts to the repartition plates of the structure, the neoprene centralizers at the exit of the guide pipes and at the damper clamp, in case that option is used.

This configuration permits to disassemble all the components of the stay without modifying the existing structure. Also, strands can be removed or replaced one by one if required.

MeKano4 has agreements with third companies which are specialized in stay damper manufacture that can equip DMK Stays with external or internal dampers against wind induced vibrations.

Adaptability and flexibility is also one important advantage of the DMK Stay System and the team of technicians behind it.

Stays can be adapted to use most kinds of 0.6" prestressing strands, as self protected, unbonded, galvanized or just standard ones, either of 15.2 or 15.7 mm. of both grades, 1770 N/mm<sup>2</sup> or 1860 N/mm<sup>2</sup>

As standard, DMK Stay uses light weight coloured coextruded polyethylene duct. Other ducts can also be used; thicker polyethylene ducts for cement or wax grouting of the stay free length, ducts with outer helix against wind excitation, stainless steel or painted carbon steel ducts.

The bottom part of the free length stays can incorporate antivandalism steel tubes for additional mechanical protection.

Anchor heads can be adapted to fit special requirements of the structure, small spaces, outer anchorage tubes, fork end type. Stay also may be adapted to be used at deviated stay configurations with saddles.



## Material General Specifications

For the design and manufacturing of all the components of MK4 DMK Stays only high quality materials according to international standards as fib Recommendations for Stay Cable Systems with Prestressing Steels and PTI. Basically materials required are:

- High-tensile prestressing steels as main tensile elements (according to prEN 10138 Parts 1-4, NF A 35-035, BS5896, ASTM 416M between others),
- Standardized structural steels used for anchorage and saddle components (according to EN 10025, EN 10083),
- Zinc or other corrosion-protective coatings on the prestressing steel or structural steel components,
- Stay pipes made of HDPE (High Density Polyethylene). In some cases they may be made of steel or stainless steel. PE/PP sheathing on prestressing strands,
- Filling materials such as wax and grease for the protection of the free length and anchorage,
- Rubber or poly-chloroprene rubber for guide deviators or damping devices.

## Quality

MeKano4 has developed a complete Quality Assurance Programme conforming to ISO 9001:2000 and according to the requirements of the new European code ETAG-013 for Postensioning, including the design, production, supply and installation of all the required PT works, as anchorages, auxiliary equipment; pushing strands, stressing and injection. By this way, this complete quality system covers all postensioning work performed by MeKano4.





## DMK Anchor Heads

Stay anchor heads are the intermediate devices that transfer the force of the tensile element of the stay to the structure and vice versa.

The working principle of these anchors is similar to the ones of standard post-tensioning.

They are based in conical wedges that grip the strands. However, requirements for these stay anchorages are different to those of the post-tensioning.

Wedges are specially designed to withstand by themselves the dynamic and static force behaviour of the stay.

Inside the anchor, strands keep its 4 protection barriers, their axis deviate from its position at the bundle inside the duct to spread to the position at the anchor head plate and the strands bear only against plastic except at the wedge grip.

Anchor head shall also permit the stressing of the strands by monostrand jack and, depending on its type, allow for fine adjustments by global hollow jacks.

Anchor shall keep the 4 barrier protection to the steel of the strand, it also has to deviate the strands internally from its distribution at the anchor plate to the one at the polyethylene duct.

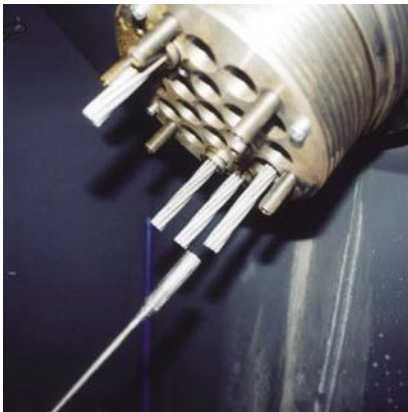

## Anchor heads comprise the following zones

- Anchorage outer zone  
Comprises two protection caps, one over the anchorage plate filled with wax to protect the wedges and the strand tails. The other to protect all the anchorage that protrudes from the bearing plate of the structure.
- Anchorage plate  
Comprises the plate and the wedges, at the fixed end anchorage type comprises also the anchorage bearing nut.
- Wax chamber tube  
Comprises the wax and the tube that conforms the wax chamber, at the adjustable end this tube is an adjustable threaded socket with the bearing nut.
- Sealing pack  
Comprises the sealing mastic, the strand deviators and its body frame.
- Deviator tube  
Is the extension tube that provides the required length to deviate the strands from the anchorage plate diameter to the duct diameter. This tube comprises elastomeric hinges to allow certain angular deviations from the stay axis to the anchorage axis.
- Centraliser zone  
Comprises the diaphragm that links transversally the strands to the centraliser. It also comprises the attachment for the duct.



Stay Elements	
1	Anchorage Outer Zone
2	Bearing Plate
3	Guide Pipe
4	Centraliser
5	Anti-Vandalism Pipe
6	Polyethylene Telescopic Tube
7	Polyethylene Duct
8	Self-Protected Strands

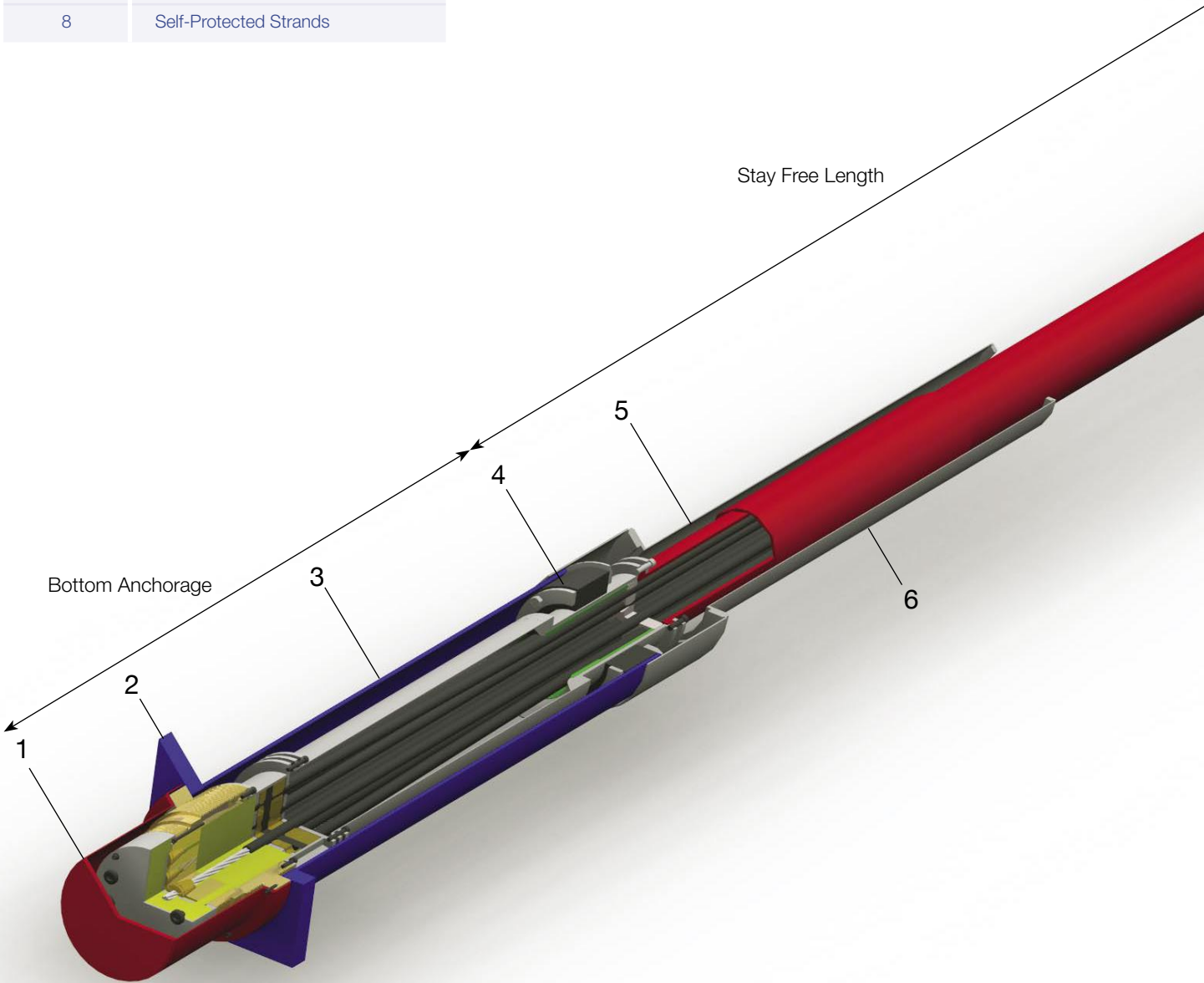



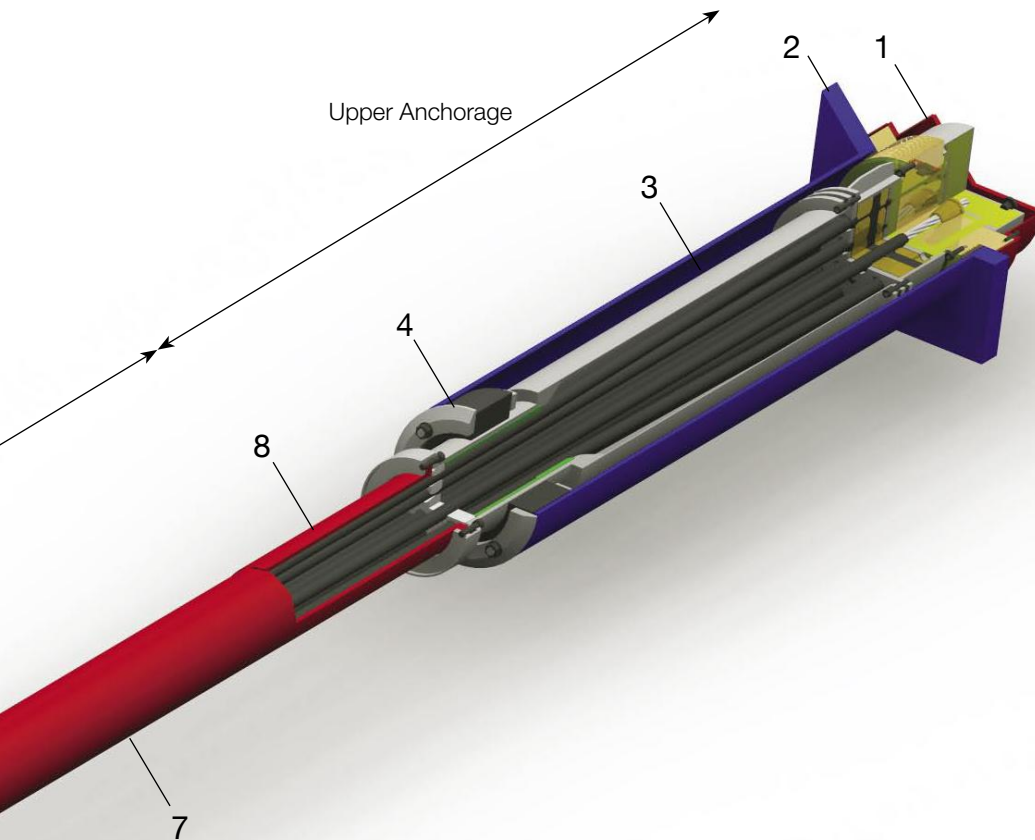

## DMK - Parallel Strand Stays Characteristics

Stay type	N° of Strands	Nominal Breaking Force ( $f_{pk}$ )	Maximum Design Force (45% of $f_{pk}$ )	Maximum Dynamic Range	Prestressing Steel Section	Approximate Elastic Stiffness ( $E \times A$ )	Stay Linear Mass	Strand Weight
	Unit	kN	kN	kN	mm <sup>2</sup>	MN	Kg/m	Kg/m
DMK-7/0.6"	7	1.953	879	210	1.050	205	10,95	8,19
DMK-12/0.6"	12	3.348	1.507	360	1.800	351	18,01	14,04
DMK-19/0.6"	19	5.301	2.385	570	2.850	556	27,21	22,23
DMK-24/0.6"	24	6.696	3.013	720	3.600	702	34,48	28,08
DMK-31/0.6"	31	8.649	3.892	930	4.650	907	44,45	36,27
DMK-37/0.6"	37	10.323	4.645	1.110	5.550	1.082	53,16	43,29
DMK-43/0.6"	43	11.997	5.399	1.290	6.450	1.258	61,02	50,31
DMK-55/0.6"	55	15.345	6.905	1.650	8.250	1.609	78,01	64,35
DMK-61/0.6"	61	17.019	7.659	1.830	9.150	1.784	87,28	71,37
DMK-73/0.6"	73	20.367	9.165	2.190	10.950	2.135	103	85,41
DMK-85/0.6"	85	23.715	10.672	2.550	12.750	2.486	120,53	99,45
DMK-91/0.6"	91	25.389	11.425	2.730	13.650	2.662	128,39	106,47
DMK-109/0.6"	109	30.411	13.685	3.270	16.350	3.188	154,49	127,53
DMK-127/0.6"	127	35.433	15.945	3.810	19.050	3.715	181,07	148,59

Note: Characteristics for straight, not grouted, Stays with strands 0.6" as per prEN-10138-3

Strand Type and Standard	$f_{pk}$	Nominal Diameter	Cross Section	Minimum Breaking Load $f_{pk}$	Yield Strength 0.1% strain	Approximate Modulus of Elasticity	Linear Mass of the Self Protected Strand	Strand Weight
	MPa	mm	mm <sup>2</sup>	kN	kN/mm <sup>2</sup>	MN	Kg/m	Kg/m
0.6" / prEN-10138-3	1.860	16	150	279	240	195	1,31	1,17

## DMK Adjustable End

Besides unitary stressing with monostrand jacks, this DMK Stay anchor allows adjustments and checking of the stay force actuating globally in the totality of the strands by pulling or releasing all the anchor head.

To do so, anchorage plate bears over a threaded cylindrical socket with nut. This nut is the element in contact with the bearing plate of the structure. Force goes from the strand to the anchor head plate through the wedges and from this plate to the structure through the socket and the nut.

Anchor head plate has an outer thread for jack attachment. When pulling this plate, the socket and its nut follow the movement and the strands increase its force. At this time, nut can be adjusted at a different position, screwing to keep the actual force of the stay or unscrewing to reduce the stay force when jack is released.

Plate and socket thread diameter difference allow the full distressing of a DMK stay cable.

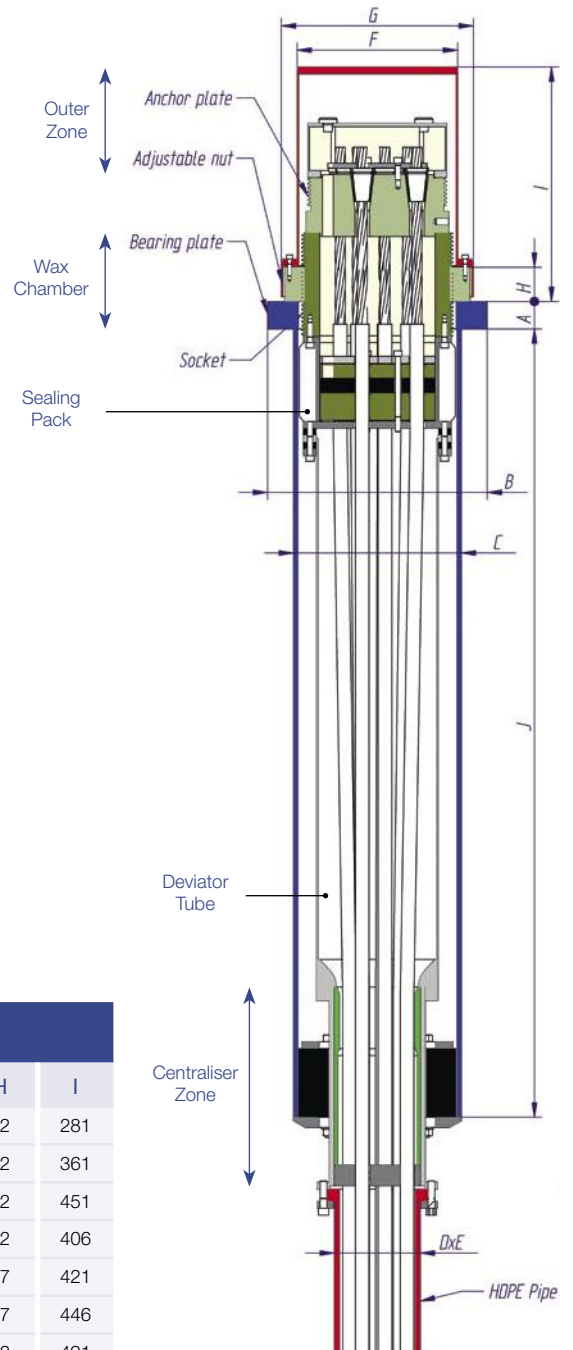

## DMK Adjustable End

Type	Bearing plate				HDPE Pipe			Head		
	A	B	C	J	D	E	F	G	H	I
7/0.6"	35	240	194	400	110	5,3	186	228	42	281
12/0.6"	40	320	244	1550	125	6,0	234	280	62	361
19/0.6"	60	400	324	1060	140	5,4	304	386	82	451
24/0.6"	70	440	352	2750	160	6,2	324	385	72	406
31/0.6"	85	490	372	2110	180	6,9	344	420	87	421
37/0.6"	95	550	389	1510	200	7,7	378	460	87	446
43/0.6"	95	580	452	3910	200	7,7	424	506	92	491
55/0.6"	115	640	472	3134	225	8,6	444	550	112	521
61/0.6"	120	680	508	2370	250	9,6	474	570	102	516
73/0.6"	130	750	558	4830	250	9,6	530	640	127	596
85/0.6"	145	795	572	3900	280	10,7	544	680	137	611
91/0.6"	150	840	610	3910	280	10,7	574	700	132	616
109/0.6"	160	910	660	5355	315	12,1	632	760	137	671
127/0.6"	175	980	711	4140	355	13,6	674	830	152	711

### DMK Fixed End

This anchorage permits the unitary stressing of the strands but doesn't allow adjustments of the stay force with global jacks.

Here the nut is threaded directly to the anchorage plate. The wax chamber tube wall is thin compared to the one of the threaded socket as it only have to support the weight of the duct. This configuration reduces the outer diameter of the anchorage as well as the size and diameter of the bearing plate and the guide pipes.

Besides its lower cost, this anchorage is indicated for reduced space places such as pylon heads.

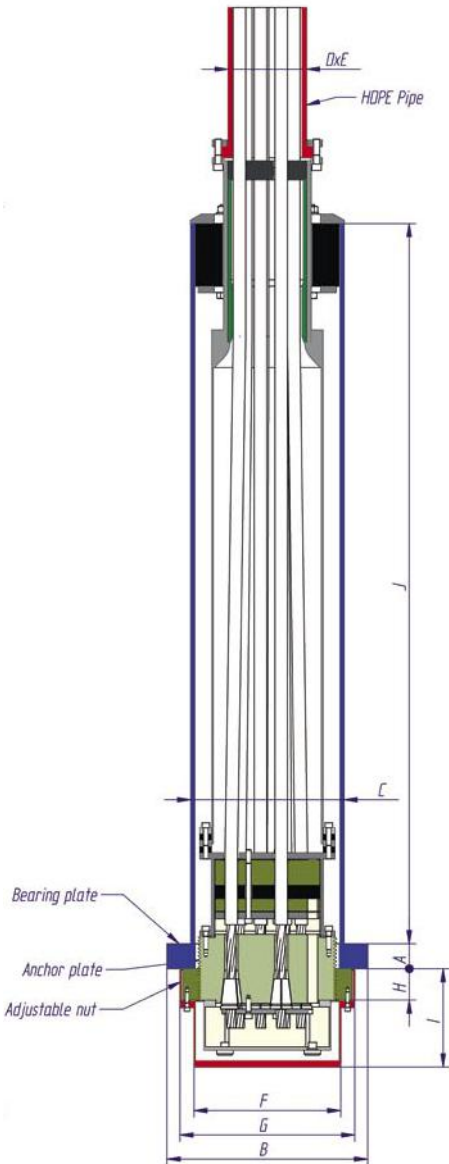

### DMK Fixed End

Type	Bearing plate				HDPE Pipe			Head		
	A	B	C	J	D	E	F	G	H	I
7/0.6"	30	227	190	400	110	5,3	174	210	38	145
12/0.6"	35	313	244	1550	125	6,0	234	270	51	158
19/0.6"	55	356	285	1060	140	5,4	274	326	62	169
24/0.6"	65	427	324	2750	160	6,2	306	366	73	180
31/0.6"	80	475	335	2110	180	6,9	322	398	87	194
37/0.6"	90	540	370	1510	200	7,7	354	444	94	201
43/0.6"	90	565	406	3910	200	7,7	396	483	98	205
55/0.6"	110	621	430	3134	225	8,6	414	522	118	225
61/0.6"	115	645	430	2370	250	9,6	414	515	123	230
73/0.6"	125	734	508	4830	250	9,6	494	616	132	239
85/0.6"	140	949	520	3900	280	10,7	809	898	148	255
91/0.6"	145	835	550	3910	280	10,7	539	693	150	257
109/0.6"	155	902	610	5355	315	12,1	594	748	163	270
127/0.6"	170	959	640	4140	355	13,6	628	798	178	285

## Saddles

There is an increasing tendency to eliminate the upper anchor heads of the stays at the pylon or tower of some stayed structures and to replace it by a saddle that deviates the stay. The stay crosses the pylon through the saddle and both of its ends anchor at the deck. This typology is becoming more and more common on extradosed bridges.

Saddles may be adherent or non adherent and they may allow for cable replacement or not. Saddles are tailored design to fulfil the project requirements.



## Strand for the DMK Stay System

The properties and characteristics of the 7-wire strand required by parallel strand cables, such as the DMK stay, have some similarities with post-tensioning strand and they shall fulfil the requirements of the applicable strand standards. Depending on the project specifications, standards such as prEN, BS, ASTM or others may be used.

However, for this type of strand, higher quality and technical requirements in terms of strength, dynamic behaviour and stress corrosion are required, besides satisfying the standards.

Self-protected cable stay strand, corresponds to a 7 wire prestressing strand, produced with galvanized wires, filled with petroleum wax and plastic coated through extrusion of black or coloured HDPE.

The main features of the strand according to the FIB recommendations are:

- |  |   |
|--|---|
| • Nominal diameter                     | 15.7 mm or 15.2 mm  |
| • Guaranteed Ultimate Tensile strength | 1.860 MPa or 1.770 MPa  |
| • Ultimate Breaking load               | >279 KN or > 265 KN   |
| • Relaxation                           | <2.5% at 1.000 hours / 20°C                                       |
| • Fatigue resistance                   | 2x10 <sup>6</sup> cycles, max. load of 45% UTS, 300 MPa variation |

### Properties of Galvanization

- Wires to be Hot Dip Galvanised before last drawn process
- Zn coating between 180 and 340 g/m<sup>2</sup>
- Adherence, coating and aspect in accordance to NF 35-035

### Properties of unitary HDPE coating

- HDPE to be produced by extrusion with virgin black or coloured HDPE
- HDPE thickness in between 1.5 mm and 2 mm

### Properties of the filler

- Filler to be placed while wires of strand are separate
- Filler to be an MK4 approved petroleum wax, grease or soft resin
- Quantity between 5-12 g/m





## High Density Polyethylene Duct

The UV-resistant high-density polyethylene (HDPE) stay pipe conforms to the FIB recommendations, PTI, and other international standards. Stay pipes may be used as a corrosion barrier. However it also provides the following properties and advantages:

- Aesthetics by use of stabilised coloured pipes
- Reduction of wind drag through the formation of a circular stay cable surface
- Protection against vibrations induced by rain and wind with appropriate surface corrugations.

For non grouted stays, using self-protected strand, the maximum Standard Dimension Ratio (SDR = ratio of outside diameter to minimum wall thickness) is in our system 26. Wall thickness shall be 5 mm. as minimum, and sufficient to withstand handling and construction loadings.

For cement or wax grouted stays, the maximum Standard Dimension Ratio is in our system 18. In this case, wall thickness shall be sufficient to withstand handling and construction loadings as well as 125% of maximum grouting pressure.

Our product, made of virgin polyethylene on qualities PE-80 or PE-100 is available in more than 100 colours including metallic effect colours, solid or co-extruded construction and several options as internal helix as spacers, external spirals to reduce cable vibrations caused by wind/light rain effect or other surface features for the state of the art for the intended use.

HDPE pipe is provided in pieces of a maximum length of 11.8 m. These segments are typically welded by mirror welding to form a continuous stay pipe. These welds shall be able to develop the yield strength of the monolithic pipe section.



## Anti-vandalism Pipes

Some bridges have a configuration that allows the access of pedestrians to the lower part of the stays free length. The telescope of the duct of the DMK Stay and the bottom elastomeric centraliser are located there. In order to avoid unauthorized personnel to reach those vulnerable parts, the use of anti-vandalism pipes is highly recommended. These pipes normally have the required length to obtain a vertical projection between 2.5 and 3 meters.

Duct hangs from the upper anchorage or saddle, working at traction, so it can remain straight during all its life, independently of its own thermal movements and the stay movements due to load changes or vibrations. This is the reason why antivandalism pipes have flexible supports and joints that allow their rotation and permit the extension or shortage of the duct.

Besides giving an additional mechanical protection to the lower part of the free length of the stay, anti-vandalism pipe can also be used for an aesthetic purpose using different materials and finishing.

Occasionally these pipes, or the bottom part of the stay duct, have been cement grouted for improved fire protection.



## Elastomeric Centraliser

Most stays cross four points of the structure, a typical arrangement would be the two anchor points and the two exit points of the guide pipes, opposite to the bearing plates. Stay is fixed at the anchor points, but depending on the construction tolerances, or due to transversal movements of the stay caused by vibrations or load variations, stay may lay over the free end of the guide pipes.

To overcome this problem, the DMK Stay incorporates an elastomeric centraliser at these points. The centraliser is a rubber ring that presses the transition tube of the stay anchor against the inner part of the guide pipe tube. Its main function is to align the stay between the exit points of the guide pipe and its anchor heads with a soft and elastic material.



## Dampers for Wind Induced Vibrations

It is well documented that the low inherent damping characteristics of the long cables used on cables-stayed bridges results in vibration with very high amplitudes. The vibrations are caused by a lifting effect on the cables that are caused by rivulets of water that are formed on the bottom of the cables during rain storms. Once a rivulet forms, the cable takes on the shape of a wing and under moderate winds, the cable is easily lifted.

DMK Stay uses a line of passive damping devices specially designed to minimize cable vibrations. These devices provide continuous energy absorption and are designed for millions of cycles without maintenance requirements.

Rigorous testing programs show that cable dampers designed for DMK Stays are effective in reducing damaging cable vibrations caused by wind and rain storms.

Though cable stay vibrations induced by the wind are normally not dangerous for the stay stability, they can drastically reduce its durability. Left unprotected, the vibrations in the highly tensioned cables can cause the fatigue of the tensile elements and even breakages of secondary elements that may reduce the public confidence in the bridge.

Even though there is not any analytical theory yet that permits to predict when a cable is susceptible of vibrating, most current recommendation establishes stay characteristic values that indicate when a stay shall be equipped with damper systems.

External cable dampers produced for DMK by Taylor Devices are attached perpendicularly to the cables and can be used for both vertical and lateral cable vibrations. The dampers are connected close to one end of the cable, most often at the deck location. In some applications, the dampers can be placed at the tower/cable interface.

The effect of the cable damper is to provide a soft damping enhancement to the vibration frequency of the cable to reduce vibration amplitude and minimize the motion.

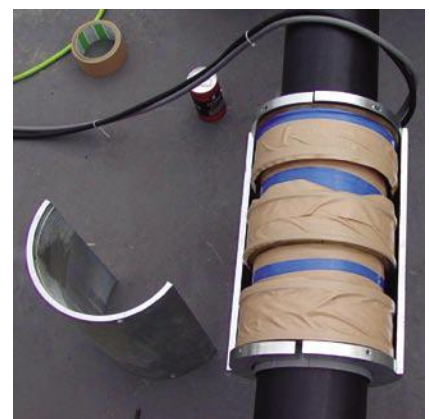



## Monitoring

DMK Cable Stays can install specially designed Dynamag elasto-magnetic sensors inside their anchorages to monitor the force of selected strands at any time during the service life of the stay.

Sensors measure the magnetic permeability of the strand. Permeability is a function of the applied magnetic field, temperature and the stress of the strand. Measurements are taken inducing a magnetic field at a known temperature, obtaining the axial stress of the strand indirectly.

These sensors are able to give good readings during the years with a remarkable precision. Besides, strands do not need any special modification for its installation.

During stay installation or stressing, these sensors are specially useful to know the force variation at some stays when stressing the others. Also they are good for force checking during maintenance operations and to analyze the effects of life load over the stay forces.



## Testing of Stay Cable Systems

The best known and experienced international associations, the Fédération Internationale du Béton (fib) and the Post Tensioning Institut (PTI), recommend three different levels of testing for stay cables:

- Initial approval testing of the stay cable system,
- Suitability testing of the stay cables system for a particular project,
- Quality control testing of the stay cable components for a particular project.

Several initial approval testing on MK4 DMK Stay Cables have been done on 61/0.6" units at different institutions in Europe.

The whole program of initial tests included fatigue tests and subsequent static load tests, carried out at the Technische Universität München (Germany) and testing on materials and installation methods, as anchorage wax injection, carried out at the Universitat Politècnica de Catalunya (Spain).

For the fatigue test and subsequent static load test, the specimen is mounted in the testing machine with the same configuration as it is intended to be used.

The test specimen is then loaded to a maximum force of 45% of its guaranteed ultimate breaking load (GUTS). Subsequently, the specimen is subjected to  $2 \times 10^6$  cycles with the maximum load 45% GUTS and a 200 MPa amplitude.

After finishing the fatigue test, the load is increased until the failure of the specimen. The maximum load reached must be more than 95% GUTS or 92% AUTS(1), whichever is greater.

(1) AUTS Actual ultimate breaking load

For every single project, all the components are carefully examined according to the Quality Control System criteria and most of the components are pre-assembled at the factory to check its accuracy and correct performance, before delivering to the jobsite. As an example, all threaded connections are in-factory threaded and unthreaded.

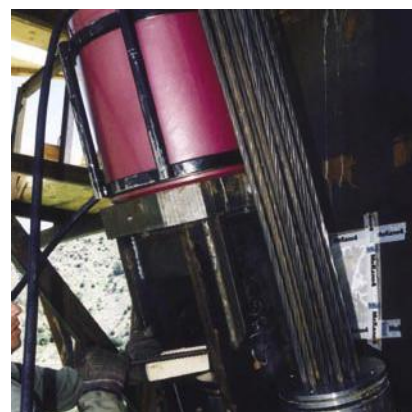
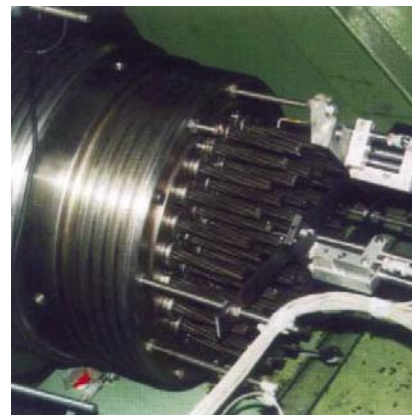





## Anchorage and Duct Installation

MeKano4 supplies the anchorage heads of the DMK Stays fully pre-assembled in order to optimise the installation cycle.

Anchorage heads can either be inserted from the exit of the guide pipe or through the bearing plate of the structure.

The duct of the free length of the stay is pre-assembled at the deck together with the anti-vandalism pipe.

Duct and its accessories are erected with cranes and the help of some auxiliary post-tensioning strands.

This Installation procedure permits the placement of duct and anchorages previous to the threading of the strands.



## Strand Threading

One of the main features of the DMK Stay System is the possibility of threading every strand directly through the anchor plate. This makes the procedure easier and quicker and allows the use of standard post-tensioning strand pushing machines.

Strand does not need to be pre-cut or peeled before threading. This operation is normally done after strand is already threaded in the stay.



## Strand Stressing

Stay can be stressed with monostrand or multi-strand jacks or a combination of both.

Stressing procedure shall be determined by the bridge Engineer.

MeKano4 Standard stressing method proposed for DMK Stays is called "stressing by elongation" and consists in the following:

- Each stay shall be stressed in at least three different phases that can be consecutive or alternated with the stressing phases of other stays.
- The first phase is realised when installing the duct, auxiliary naked strands are stressed by force with monostrand jacks. Force for this few temporary strands is equalized by stressing rounds.
- The second phase consist in stressing all the strands by force with monostrand jacks to achieve the "0" point, or initial situation for the stressing. At this phase strands are stressed at the lowest possible force level, around 15 kN by strand. This low force level allows the equalization of strands by stressing rounds. During this phase, temporary naked strands are released and replaced by definitive ones. After this phase is finished, force at the stay is measured by force average of selected strands.
- The third phase can be subdivided in some stages as per consultant requirements. This phase is stressed also with monostrand jacks but increasing



the elongation of every single strand to the same amount. This method reproduces the behaviour of a multi-strand jack that would pick up the totality of the strands and extend them the same amount till an average force.

This method is proven to be very simple and effective. For the consultant is easy to determine the stressing stages, as stay can be considered as a single unit instead of a bundle of various strands. For the site is easy to apply. It is easy to check if stressing has been realized properly, as initial marks of all the strands shall be at the same distance from the anchorage plate and equipment to be used can be as simple as a jack and a pump or as sophisticated as a machine that does the operation automatically.

A fourth stressing phase can be added to the previous ones. This last phase is done with a global hollow jack that pulls all the adjustable ends to increase, check or decrease the force of the stay.

## Finishings

The protection of the cable in the anchor head area is essential to guarantee the protection and durability of the stay. The DMK Stay anchor heads are designed to be injected with wax in a quick and easy way, getting a strong protection against the most aggressive environment.

Duct upper window is closed and sealed, as well as the bottom telescope. Centralisers are tightened and anti-vandalism pipes slide down till they bear over its support. Anchorage and duct finishing operations are independent and can be carried out simultaneously.

## DMK Commitment

The DMK Stay is having a continuous development due to the experience achieved in different projects. Installation, stressing and quality manufacture are very important factors for this development.

The fluent communication between our technical, site management and production departments has allowed us to obtain a very competitive product in technical features as well as in installation and stressing.

We learn from every single project in which we intend to manufacture with better quality, install and stress the stays in easier and better ways.

Each new project is a new opportunity which we face with excitement and our commitment is to improve the quality of the MK4 DMK Stay System regarding quality of the product and services.

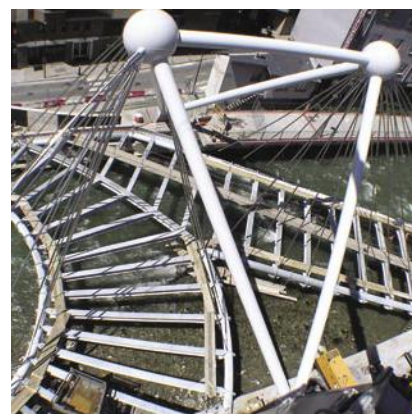
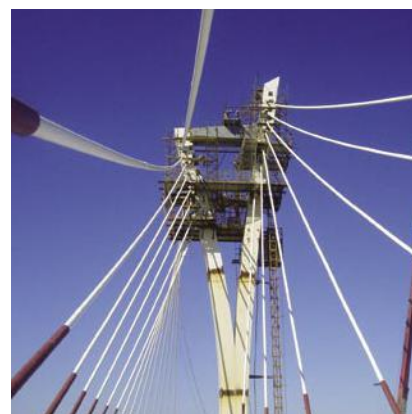



[www.mekano4.com](http://www.mekano4.com)



MeKano4, S.A.

**BARCELONA**  
Head Office

Carretera de Rubí 72-74  
Edificio Horizon  
08173 Sant Cugat del Vallés

Tel. +34 902 153 533  
Fax +34 935 706 003

[www.mekano4.com](http://www.mekano4.com)

[mk4@mekano4.com](mailto:mk4@mekano4.com)